

Features:

- Welded frame, reliable structure.
- Reversible 5mm toughened glass front door with lock.
- Removable side panels with side pins, side locks are optional for protection.
- Standing or wall mount installation.
- Cable entries on both of top cover and bottom panel.



Specifications:

- Material: SPCC cold rolled steel
- Thickness: Mounting rails: 1.5mm; others: 1.2mm
- Surface finishing: Degreasing, pickling, phosphoric, powder coated
- Static loading capacity: 60kgs

Standards:

- ANSI/EIA RS-310-D
- IEC60297-2
- DIN41494, PART1
- DIN41494, PART7
- Compatible with 19" International Standards, ETSI



Mount panel



Frame

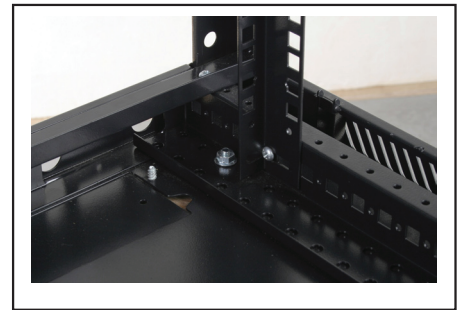

Stable structure

Optional accessories:



2U cantilever shelf



PDU



1U cable manager



Blanking panel

Structure of cabinet

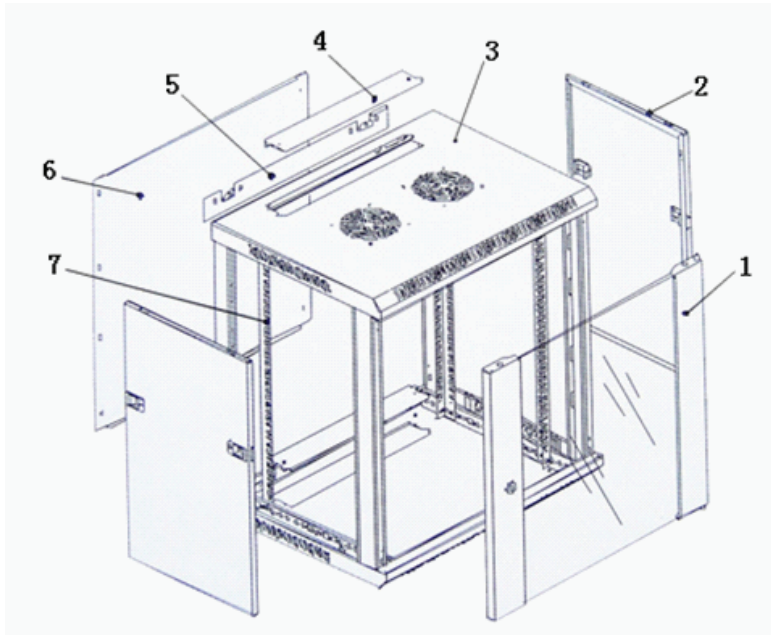

Front door options:

1-1: toughened glass door, with small round lock

1-2: toughened glass door with stripped hole border, with small round lock

1-3: toughened glass door with net hole border, with spring lock

1-4: metal plate door, with small round lock

1-5: perforated door, with spring lock

Main parts:

S/N	Specification	Qty	Unit	Material	Surface finishing	Remark
1	Toughened glass front door (1-1)	1	pc	SPCC	Powder coated	Small round lock
2	Removable side panels	2	pc	SPCC	Powder coated	---
3	Frame	1	pc	SPCC	Powder coated	---
4	Cable entry cover	2	pc	SPCC	Powder coated	---
5	Mounting panel	1	pc	SPCC	Powder coated	---
6	Back panel	1	pc	SPCC	Powder coated	---
7	Mounting rails	4	pc	SPCC	Powder coated	---
8	M6 screws and nuts	20	set	---	---	10 sets for 12U lower